

Playground Trampoline

1.MOVE

1M-T80R_S

Impact Area
Strefa upadku
Zone d'Impact
Area de Impacto
Fallraum

11,3 m²

Required surface: lawn, bark mulch, woodchip, sand, gravel
Wymagana nawierzchnia: gleba, trawnik, mulcz z kory, drobno pokrojone kawaiki drewna, piasek, żwir
Requis de surface: la pelouse, le paillis d'écorce, copeaux de bois, sable, gravier
Superficiale necessaria: erba, pacciame di corteccia, finemente tritato pezzi di legno, sabbia, ghiaia
Erforderliche Oberflächen: Gras, Rindenmulch, fein gehackt Holzstücke, Sand, Kies

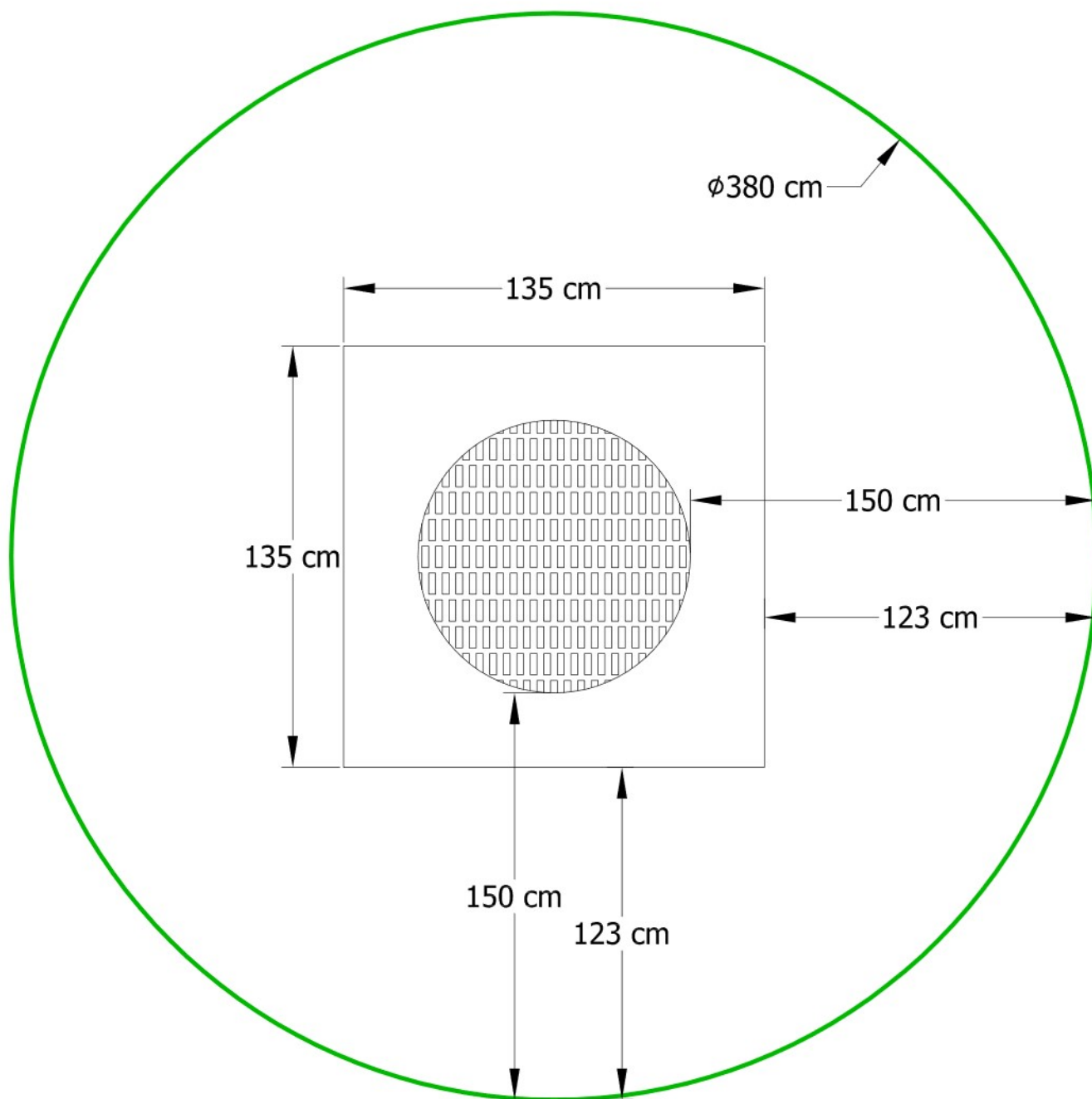

Playground Trampoline

1.MOVE

1M-T80R_S

Footing plan
Plan fundamentowania
Implanation
Implanación
Fundamentplan

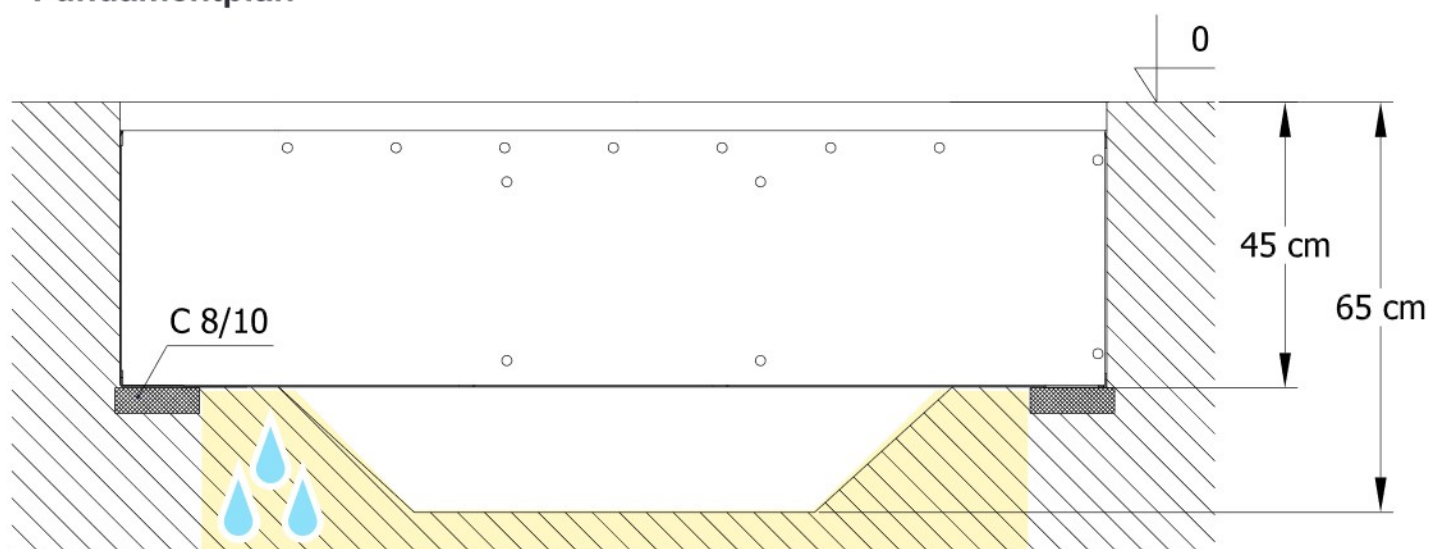

Drained undersoil / Podłoże wodoprzepuszczalne / Дренажная подсыпь

Starmax Marek Starczewski
Rycerska 3 st.
83-050 Bakowo, Poland
fitness@outdoorfitness.pl
tel.:+48 884-000-884 (PL/DE)
tel.:+48 600-250-245 (EN/RU)
www.outdoorfitness.pl



1.MOVE