

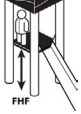







Unit Specification		
 Equipment Dimensions	6.5m x 6.6m x 3.3m	 FHF
	1.5m	
 Overall Weight	645kg	 Heaviest Part
	40kg	
 Largest Part	3.1m x 0.6m x 0.5m	 Longest Part
	3.3m	
 Maximum Gradient	1 in 50	 Construction Space
	8.5m x 8.6m x 5.3m	
 Manpower Required	2	 Estimated Time
	22 Hours	
 Concrete Required	1.2m3 SGF	 Concrete Required
	N/A	

Standard Foundation Plan - Plastic Slide

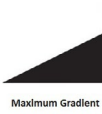
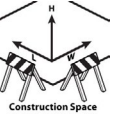

Standard Foundation Plan - Stainless Steel Slide

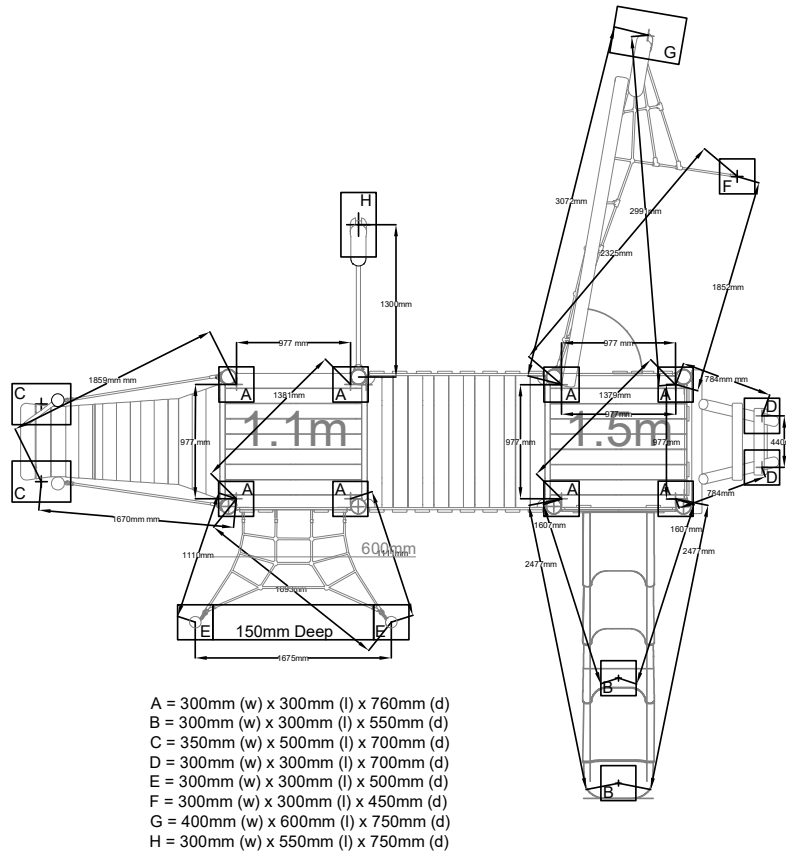