



UNIT SPECIFICATION

<p>Equipment Dimensions</p>	<p>3.0m x 2.5m x 2.6m</p> <p>1.6m</p>	<p>FHF</p>
<p>Overall Weight</p>	<p>253kg</p> <p>34kg (JS001X3(A))</p>	<p>Heaviest Part</p>
<p>Largest Part</p>	<p>2.9m x 0.3m x 0.14m (JS001X3(A))</p> <p>2.9m (JS001X3(A))</p>	<p>Longest Part</p>
<p>Concrete Required</p>	<p>0.58m³</p> <p>10.5m x 5.8m x 3.8m</p>	<p>Construction Space</p>
<p>Manpower Required</p>	<p>3</p> <p>5 hours</p>	<p>Estimated Time</p>
<p>Bolt length measured as diagram.</p>		

COMMON PARTS LIST

Part	Qty	Image	Description
TTS1	1		Team Swing Top Pole Assembly Inc. Shackles
AT22	4	*may be preassembled to top pole	M12 Shackle Assembly (Not Required for AntiWrap)
F087	8		M12 x 100mm Hex Head Bolt
F112	16		M12 Washer 32mm O/D
F115	16		M12 Washer 24mm O/D
F138	16		Nylock Nut
F600A	16		Plastic Counterbore Washer
F600B	16		Plastic Counterbore Plug
F735	8		M12 X 170mm Coach Bolt
F680A	8		Plastic Shroud
F680B	8		Washer
F601C	8		Plastic Dome Cap
F423	2		M8 x 30mm Security Bolt
F108	4		M8 S/S Washer
F419	2		M8 S/S Nylock Nut

ADDITIONAL STEEL IN GROUND PARTS LIST

Part	Qty	Image	Description
JS001X3(A)	1		Main Vertical Pole
JS001X3(B)	1		Main Vertical Pole
JS002X3	2		Support Vertical Pole
SGF001	8		Steel in Ground Bracket

ADDITIONAL SURFACE FIXED PARTS LIST

Part	Qty	Image	Description
SF001	4		Surface Fix Bracket Inner
SF002	4		Surface Fix Bracket Outer
JS008(A)	1		Main Vertical Pole
JS008(B)	1		Main Vertical Pole
JS009	2		Support Vertical Pole

SEAT OPTIONS

Part	Qty	Image	Description
SEAT7	0-1		Team Swing Orange
SEAT8	0-1		Team Swing Green
SEAT9	0-1		Birdnest Seat

Surfacing Specification

Loosefill Area

NOT TO SCALE

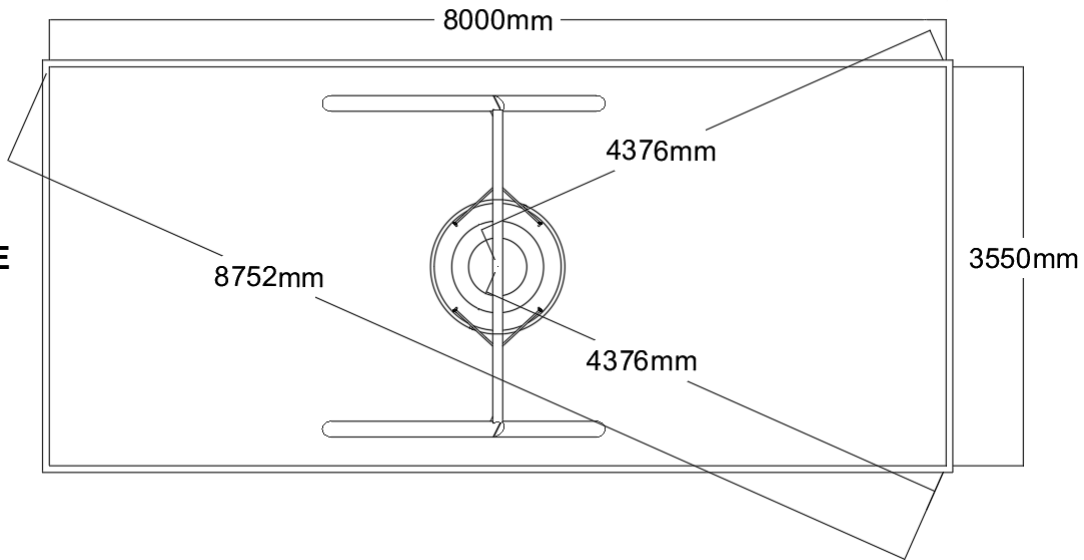

EN 1176 Impact Area

NOT TO SCALE

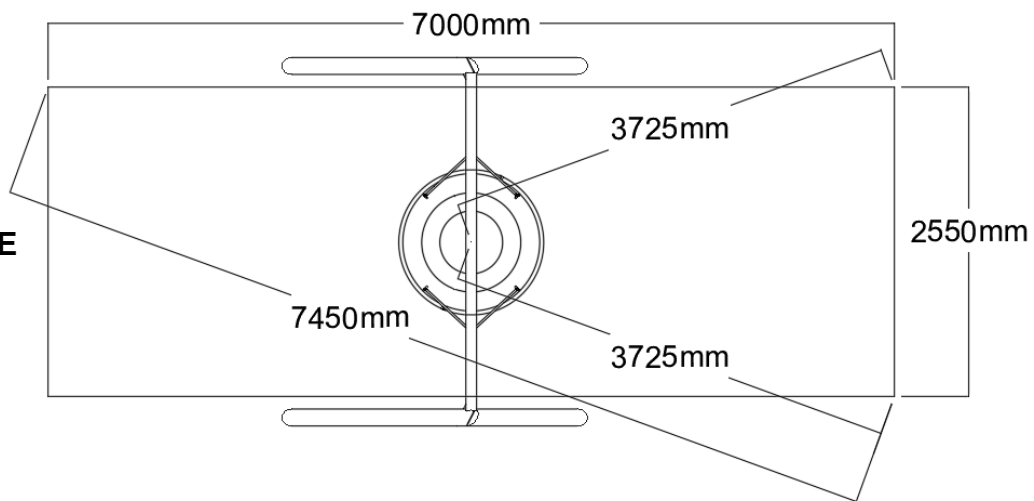

Dimensions given are absolute minimums. Must not be lower than values given!

SURFACING SPECIFICATION

Finished Gradient	1 in 50 max
f.h.f.	1.6m
Impact Area	18m ²
Impact Area Perimeter	19m
Loosefill Area	28m ²
Loosefill Area Perimeter	23m

Swing Positioning recommendations

When fully enclosing swings with fences/walls etc. They should be positioned a minimum of 1.5 metres from side edge of swing seat and 1.5m from the impact area in the direction of swing. They should have one or more entrances in corners of the enclosure nearer the centre of the playground to discourage children from waiting around the swings.

When positioning near fences/walls etc. but not fully enclosing. The swing should be positioned a minimum of 1.5 metres from the side edge of the swing seat, 0.5 metres from the impact area in one direction of swing and 1.5 metres from the impact area in the opposite direction of swing.

Standard Foundation Plan

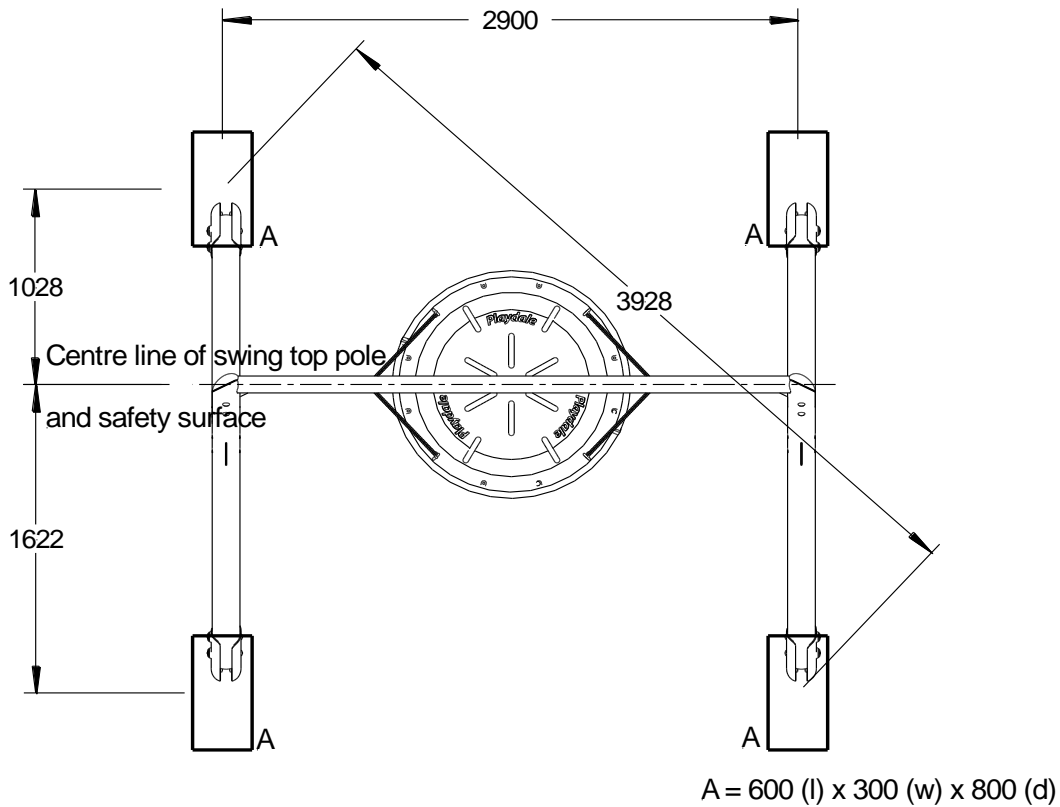

0.58m³

Minimum Concrete Specification: C16/20 (20 N/mm² min. compressive strength)
 Recommended Mix: 1 part cement/ 2 part sand/ 4 part stone.

NOT TO SCALE

Standard Foundation Detail

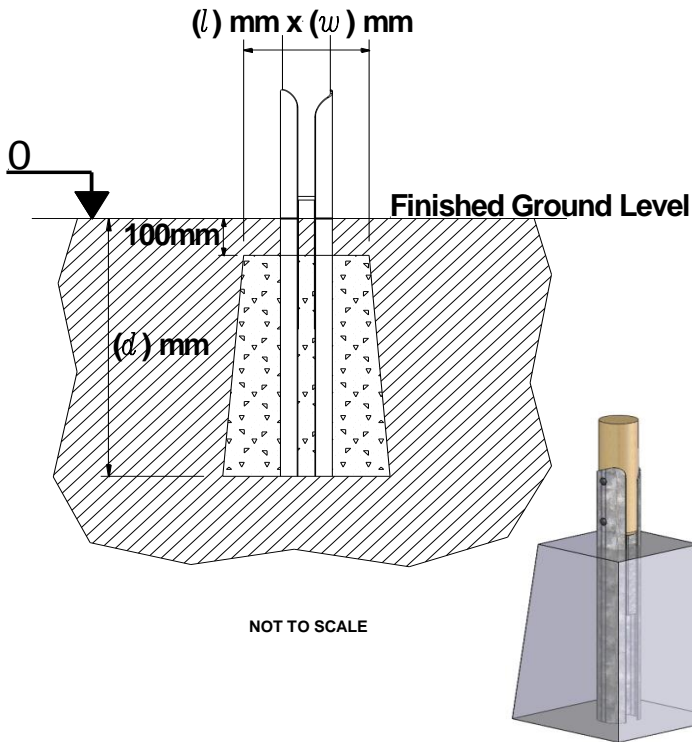

NOT TO SCALE

Loosefill Foundation Detail

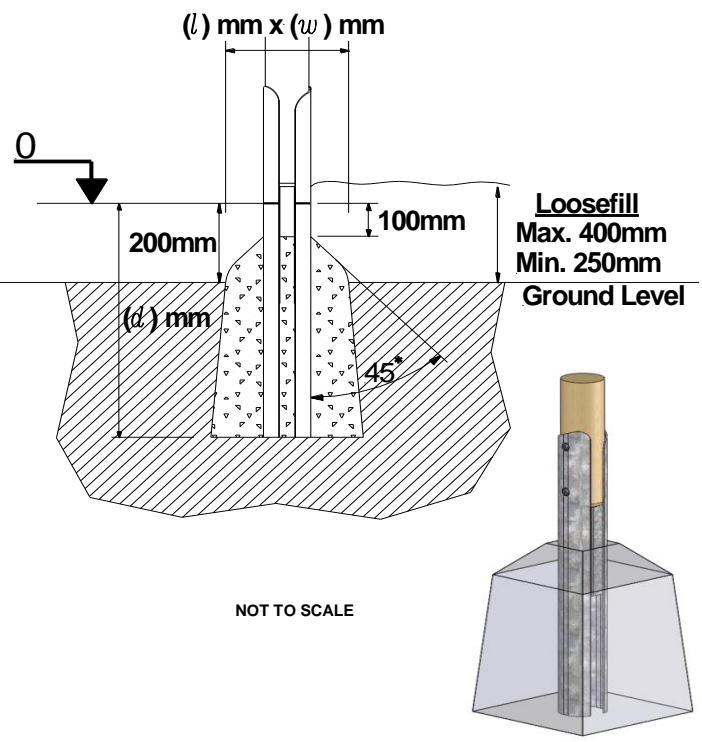

NOT TO SCALE

NOTE: All holes must taper out from hole width at top of hole (as shown) to give maximum stability. In loose or sandy ground all hole width dimensions should be increase by approximately 50%.

Surface Fixed Foundation Detail

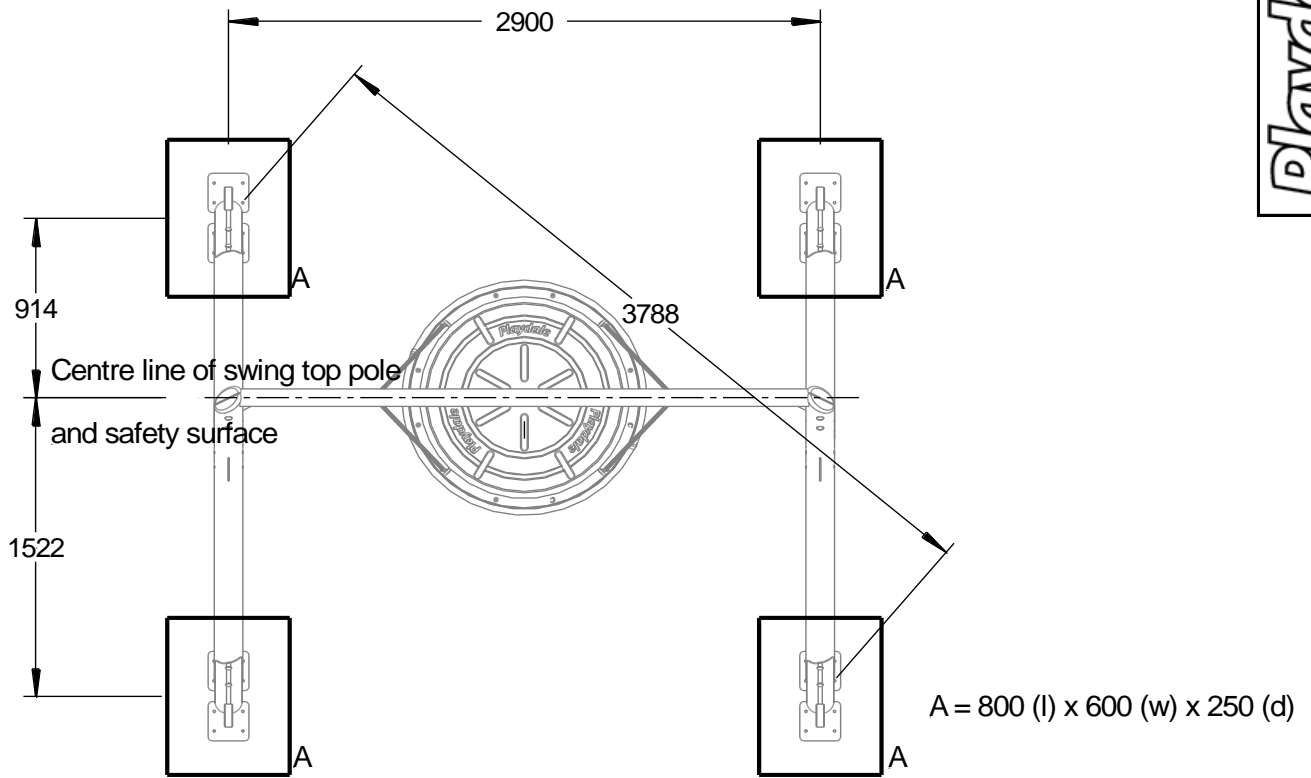

0.48m³

NOT TO SCALE

Nominal Surfacing Depth (s) = 70mm
(Allowance 50 - 100mm)

Foundations **MUST** be level, separate foundation **MUST** be level with each other. (maximum gradient 1 in 500)
 Minimum Concrete Specification: C20/25 (20 N/mm² min. compressive strength)
 Vertical loading pattern to assess existing concrete foundations available on request.
 Playdale's surface fix system has been designed for use with an M12 Resin/Adhesive Anchor system
 [Recommended Load (Tensile) 15kN minimum] using appropriate threaded stud/rod and Anti-Vibration Nut.
 All Plates and fixings should be covered appropriately as not to cause impact or trip hazard.

Surface Fixed Foundation Detail

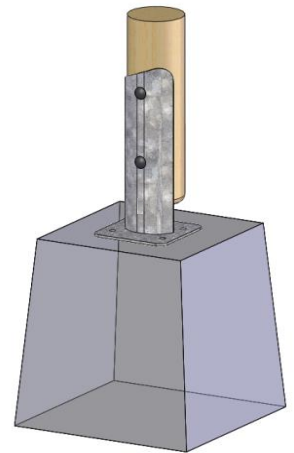
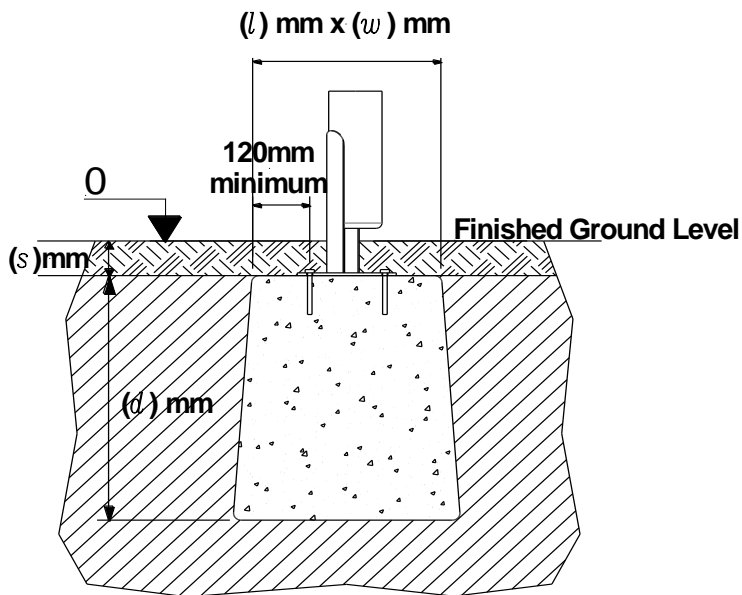

NOT TO SCALE

NOTE: All holes must taper out from hole width at top of hole (as shown) to give maximum stability. In loose or sandy ground all hole width dimensions should be increase by approximately 50%.

1 SURFACE FIXED ONLY

JS008(A)	1
JS008(B)	1
JS009	2
SF001	4
SF002	4
F735	8
F680A	8
F680B	8
F138	8

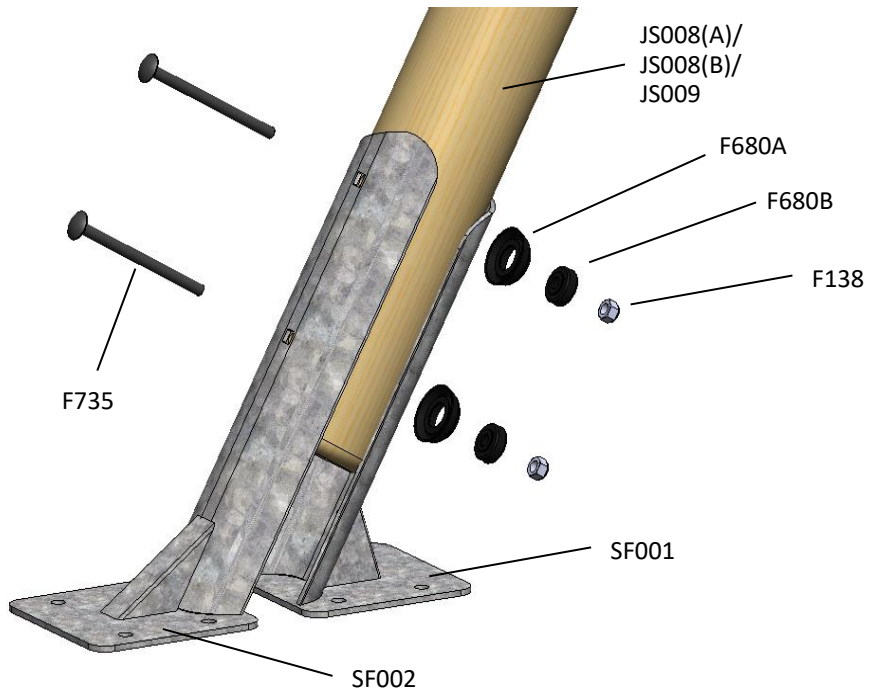
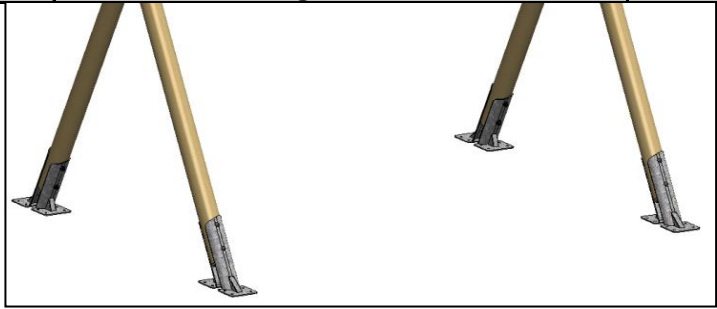

1 STEEL-IN-GROUND ONLY

JS001X3(A)	1
JS001X3(B)	1
JS002X3	2
SGF001	8
F735	8
F680A	8
F680B	8
F138	8

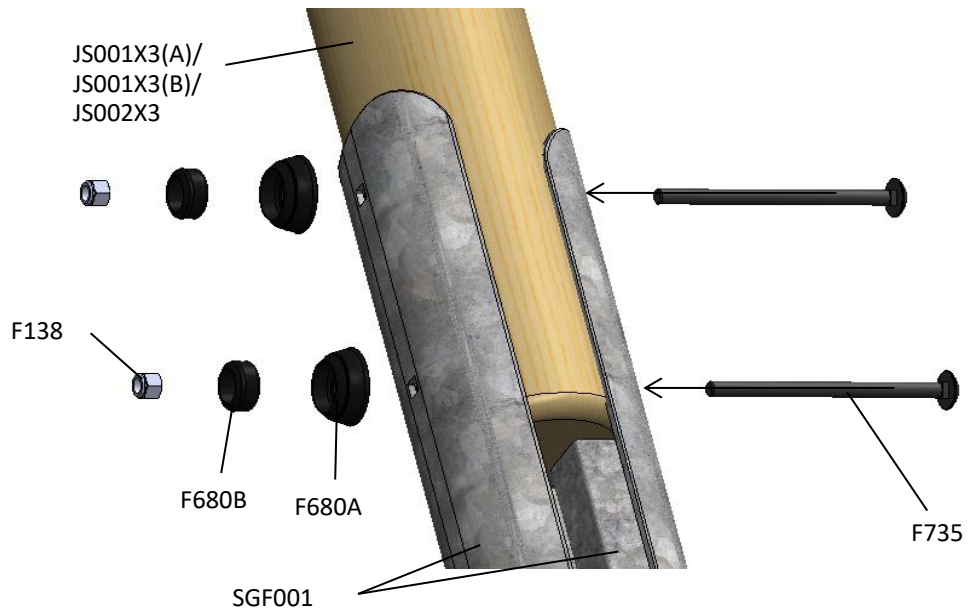
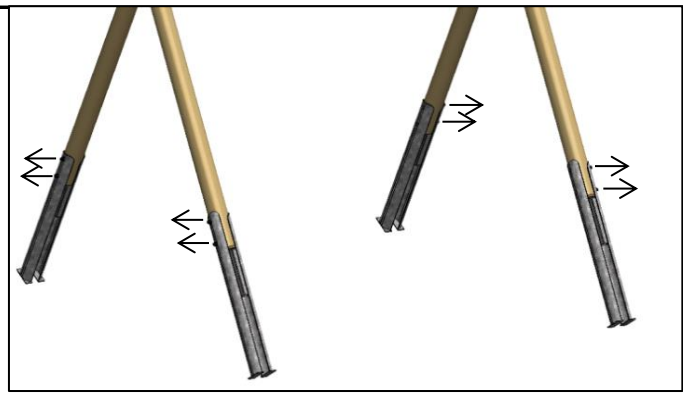

2

F087	2
F112	4
F115	4
F138	2
F600A	4

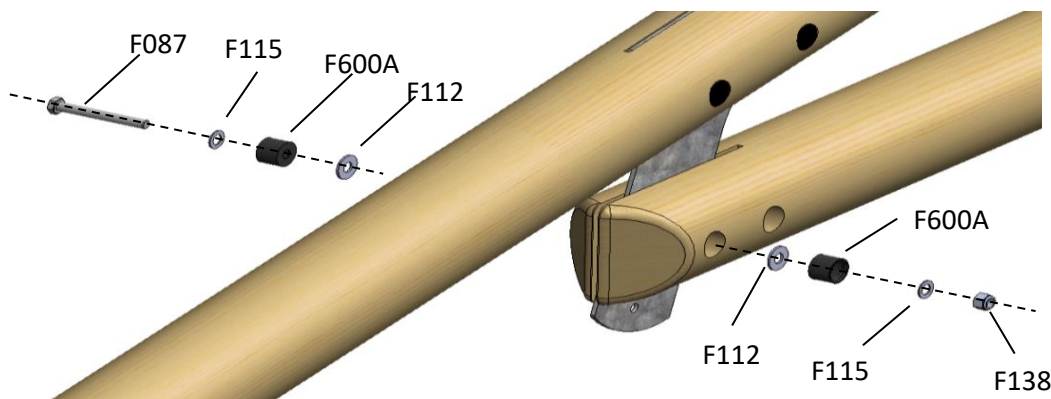
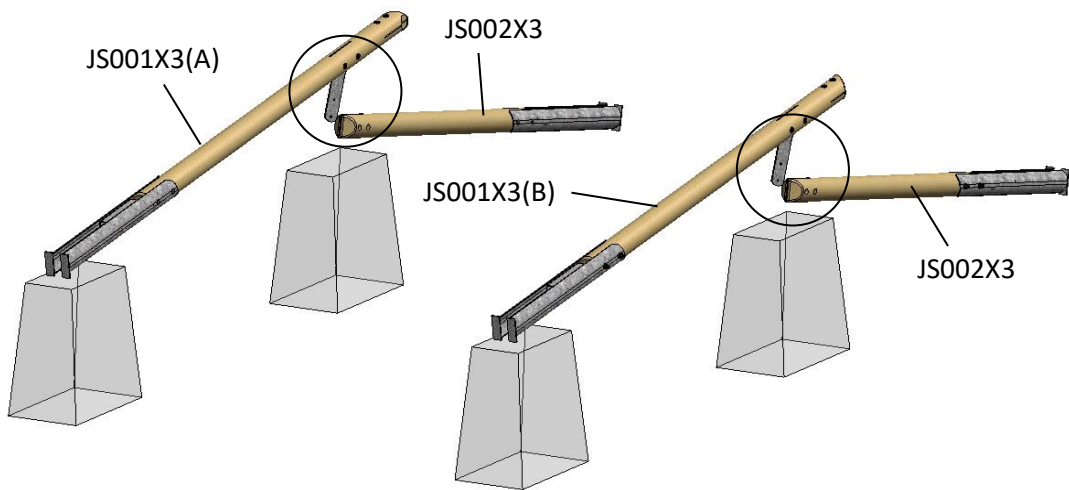

3

TTS1	1
F087	4
F112	8
F115	8
F138	4
F600A	8

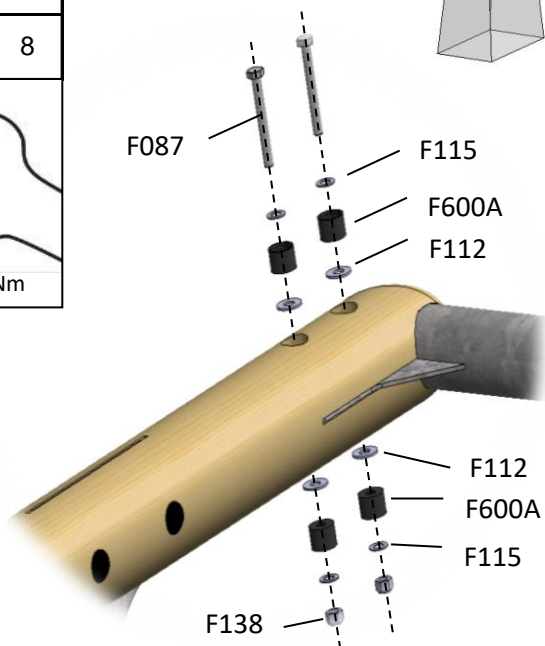
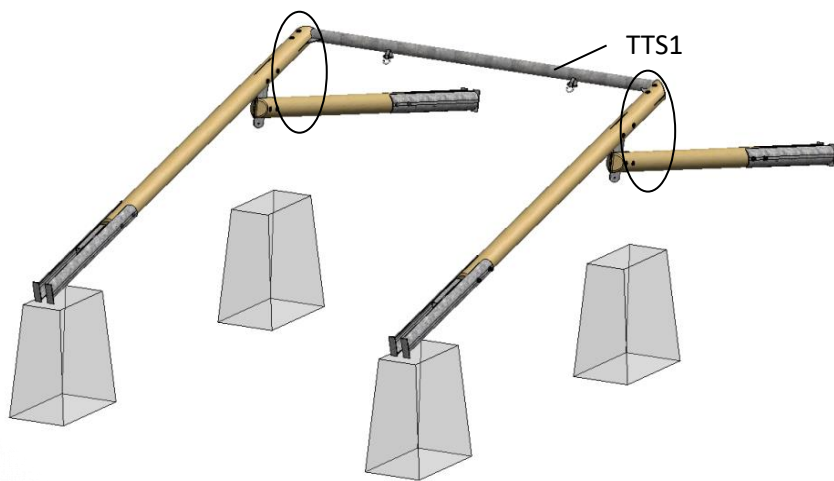

4

F087	2
F112	4
F115	4
F138	2
F600A	4

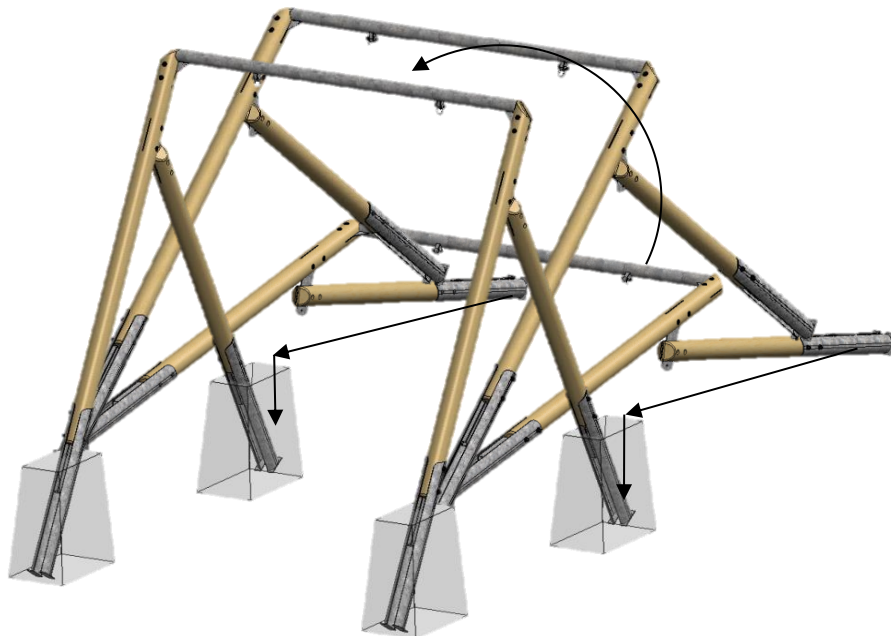

Torque to 20Nm

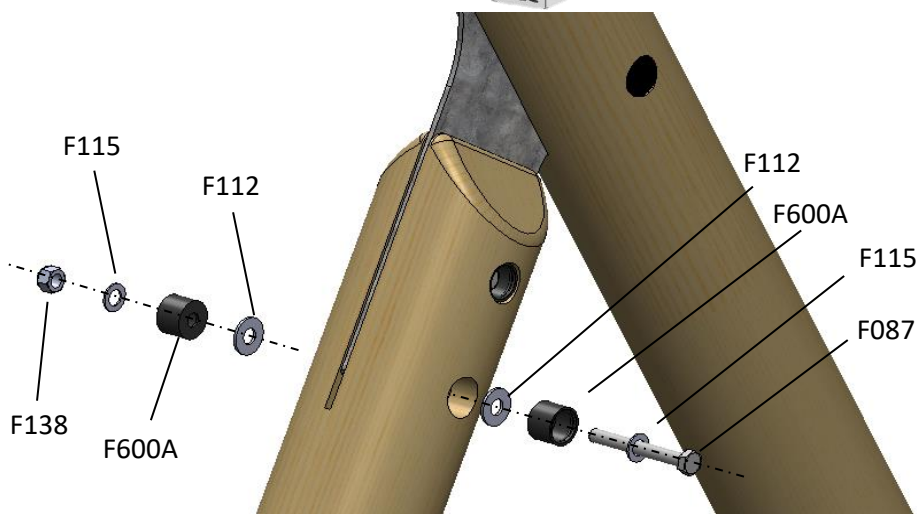

5

F600B	16
F601C	8



All Caps



Concrete

2525mm ± 20mm

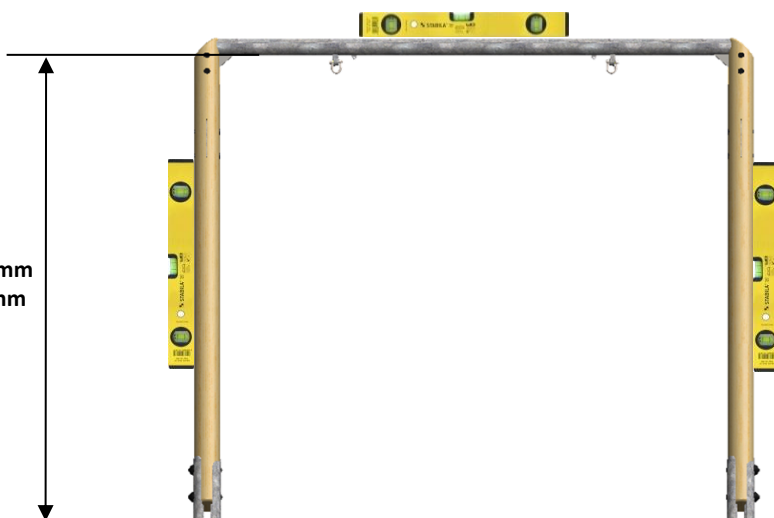

Finished Ground Level



F600A - F600B

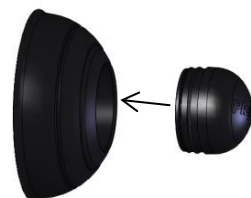

F680A - F601C

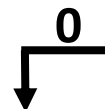

6

After 2-3 days

Standard Team Swing Shackle Assembly (JS004AX1B)

JS004AX1B 1

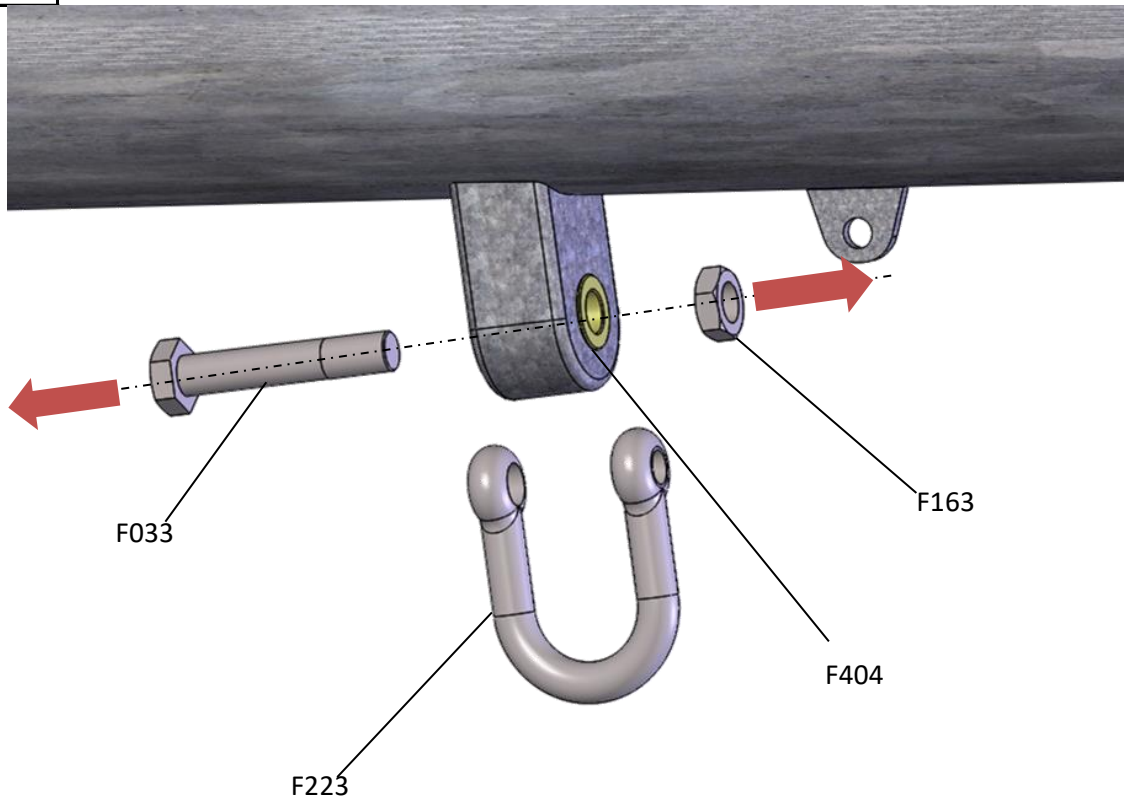

7

JS004AX1B 1



Torque to 20Nm

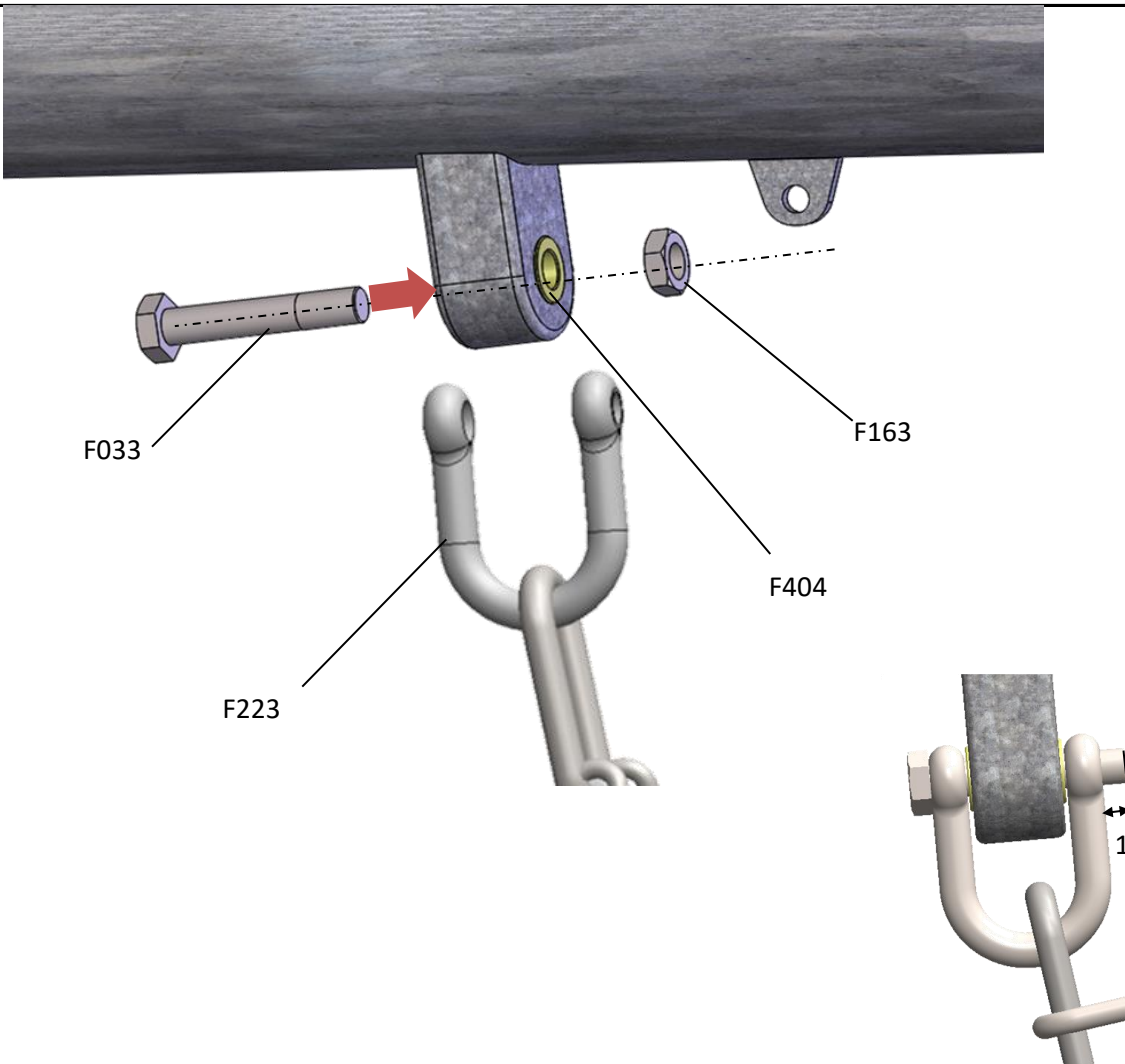

8

F423	2
------	---

F108	4
------	---

F419	2
------	---



Torque to 20Nm

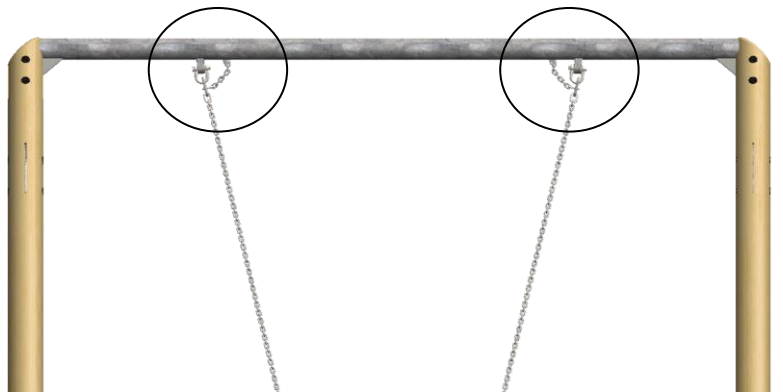
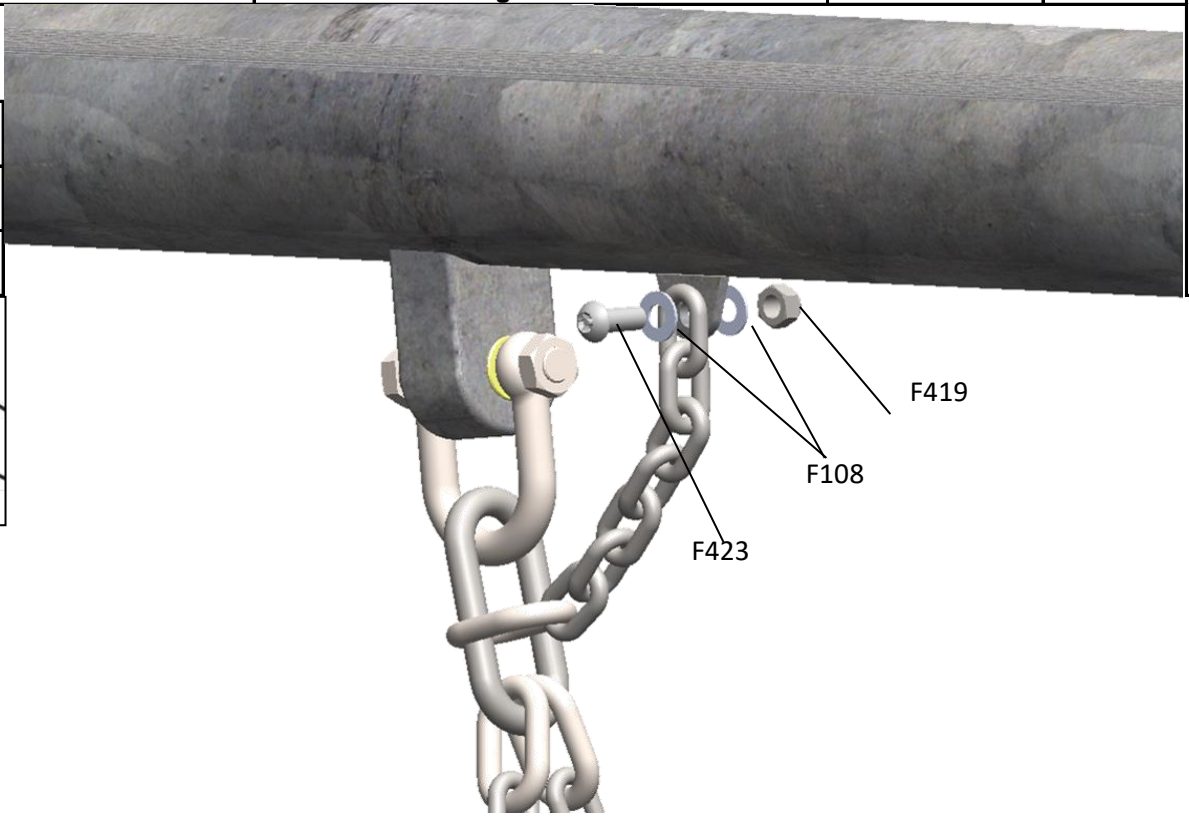

9

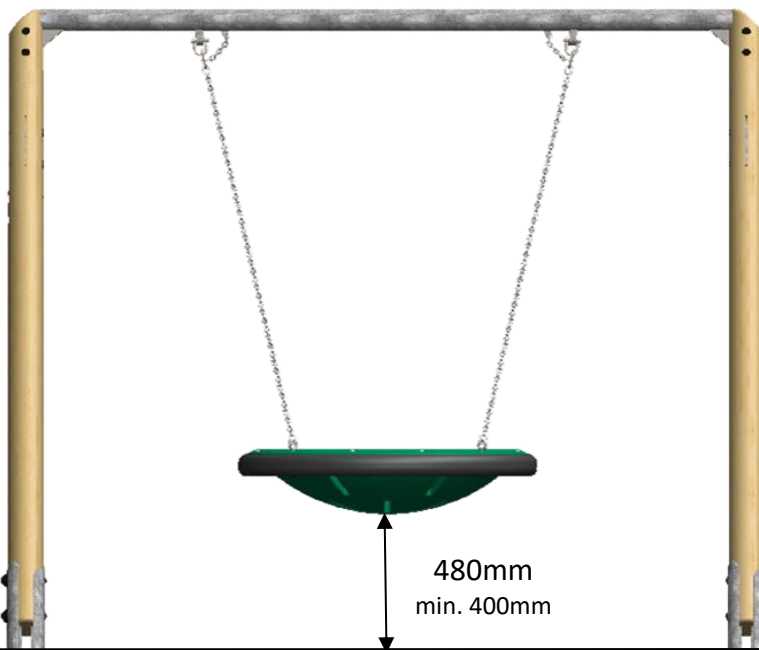

Finished Ground Level