

IMPORTANT!

INFORMATION ABOUT THE USE OF ELECTRICAL HEIGHT ADJUSTABLE CHANGING TABLE

- Never leave the child unattended on the changing table
- The remote should be placed out of reach of small children. Switch off after use
- Be aware of other children in the room while in use
- Be aware of things placed underneath the changing table
- Changing table only to be used by the staff
- Please read the complete manual and remember to instruct new staff about the use of the changing table



ELECTRIC HEIGHT ADJUSTABLE CHANGING TABLE

ConSet® - Type BSR 102+104+109

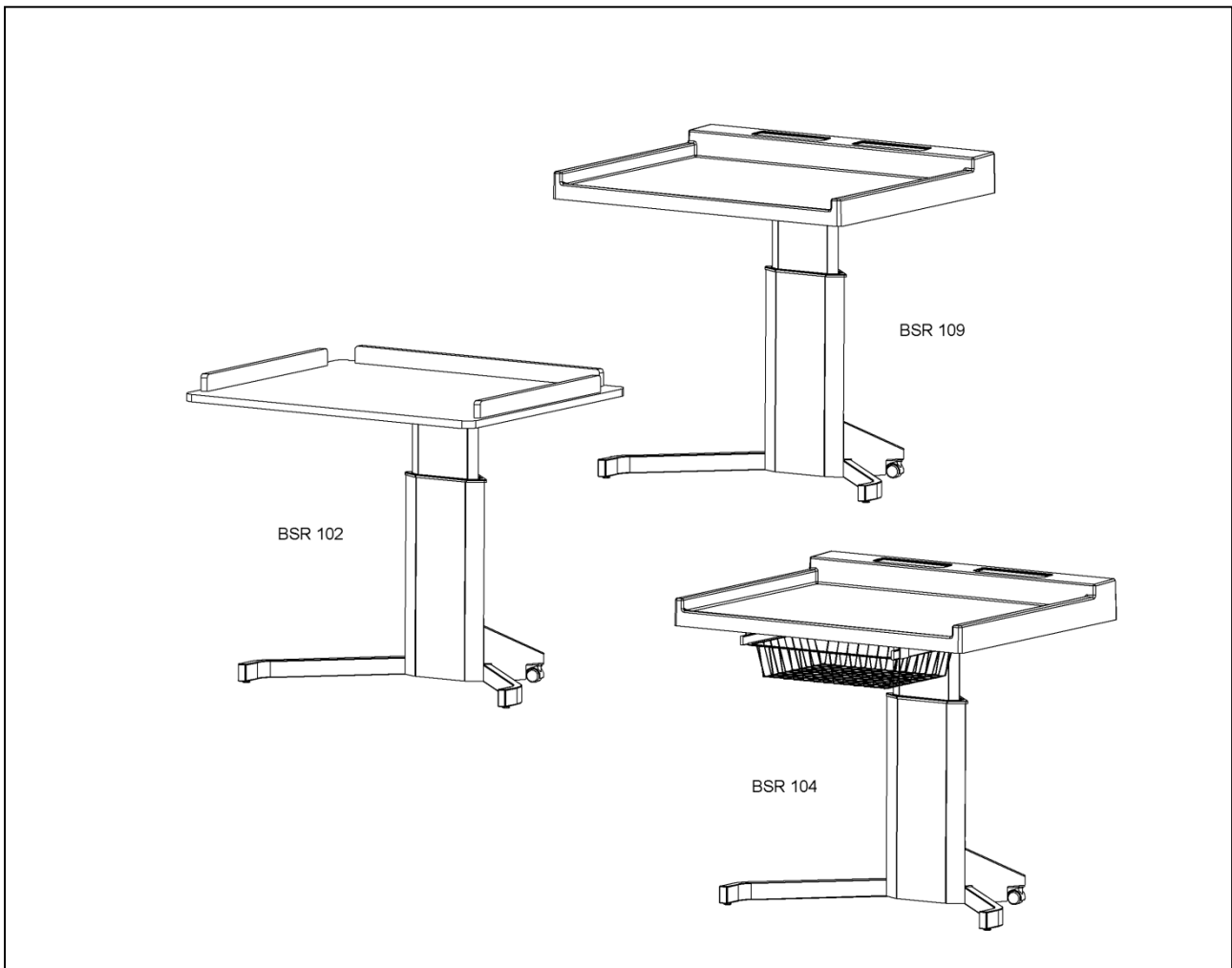

DIRECTIONS FOR USE / ASSEMBLING

EN



IMPORTANT NOTES!

Prior to installment, use and maintenance of the table frame, any installer and any user of the changing table must study this assembly and operation manual carefully, so as to gain a complete understanding of its contents.

TABLE OF CONTENT

1. SAFETY AND WARNINGS
2. USAGE
3. SET UP AND INSTALLATION
4. OPERATION
5. MAINTENANCE AND DEFECTS
6. TECHNICAL DATA
7. ASSEMBLY DIRECTIONS
8. DECLARATION OF CONFORMITY

1. SAFETY AND WARNINGS

- This changing table complies with the prescribed safety regulations. Inappropriate use may cause damage to persons and table.
- Please read the operation manual prior to using the changing table. It provides you with important information about safety, use, installation and maintenance of the table, and thus protecting you and your children to avoid injury or damage to the table.
- Please keep this operation manual and pass it on to any future owner!

2. USAGE

Usage:

- The electrical height adjustable changing table is designed to be used indoors in a dry atmosphere (0-40 °C; 20-90% relative humidity)
- For children 0-36 months.
- The changing table height is infinitely adjustable so that it can be set to the most ergonomically suitable working level of the staff in a day care center or public day care
- They have not been designed for other purposes than those included in this manual, e.g. they are not to be used in areas of high humidity or dampness, nor for lifting adults. Any other use is at one's own risk!

Safety routines:

- Never leave the child unattended on the changing table
- THE REMOTE should be placed out of reach of small children. Switch off after use.
- Be aware of other children in the room while in use. Do not crawl, lie or move around under the changing table.
- When placing the changing table always maintain a safe distance from other furnishings to avoid pinch points.
- The changing table is only to be used by the staff. The changing table is a work station, not a toy.
- The remote control must not be used if there are any signs of damage or excessive wear and tear.
- If changing tables are mounted side by side a partition wall should be mounted to minimize risk of pinch points.

Liability:

The manufacturer accepts under no circumstances warranty claims or liability claims for damages arising from the improper use or handling of the table frame other than that described in this operations manual.

3. SETUP AND INSTALLATION

The changing table must be mounted by a skilled fitter or craftsman. All directions of this manual must be followed carefully. Upon assembly, the fitter must place page 1 of this manual near the changing table.

4. OPERATION

Push the buttons to adjust the height. When the button is no longer pushed, the changing table will stop.

BSR 104

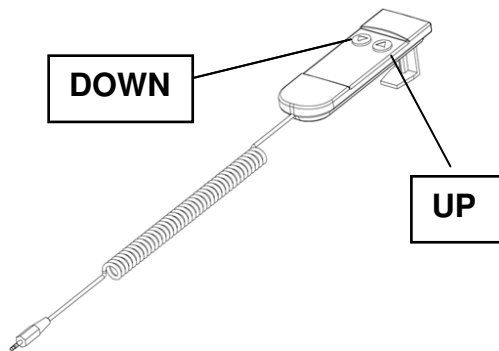

BSR 102 + 109

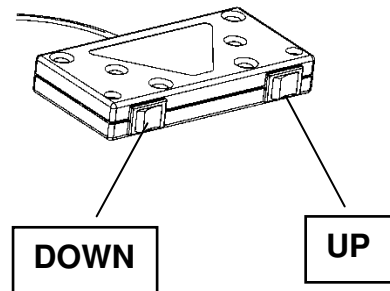

5. MAINTENANCE AND DEFECTS

- The changing table is only to be maintained with a wrung cloth. The changing table can under no circumstances be hosed down.
- In the event of the occurrence of jarring sounds during operation, STOP using the table immediately.

6. TECHNICAL DATA

Frame, materials:	Steel, powder coated
F_{MAX} = Max. load on changing table	50 kg
Operation:	Up/down push button
Voltage:	100-240 VAC / 50-60Hz
Consumption:	80 Watt
Standby consumption:	< 1 watt

7. ASSEMBLY INSTRUCTION

a) Assemble foot and top support

1

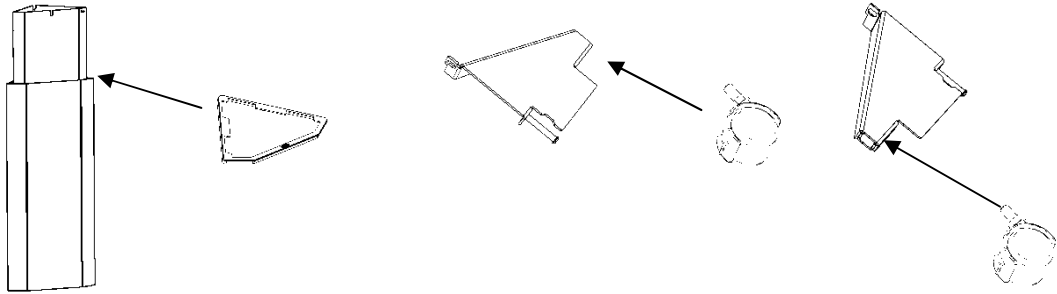

2

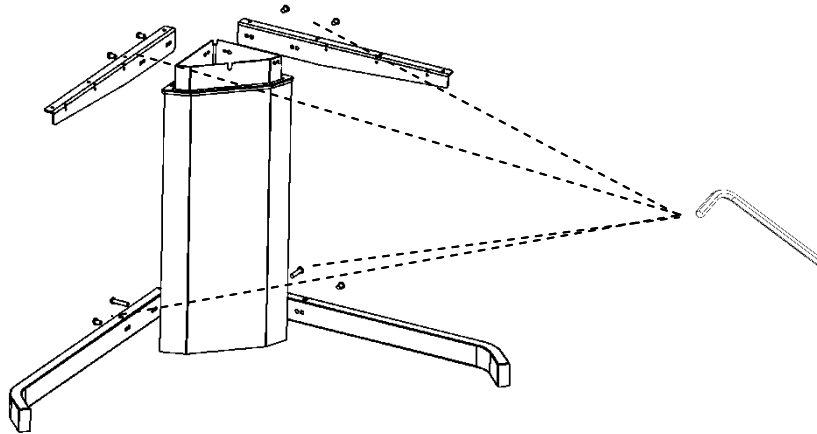

3

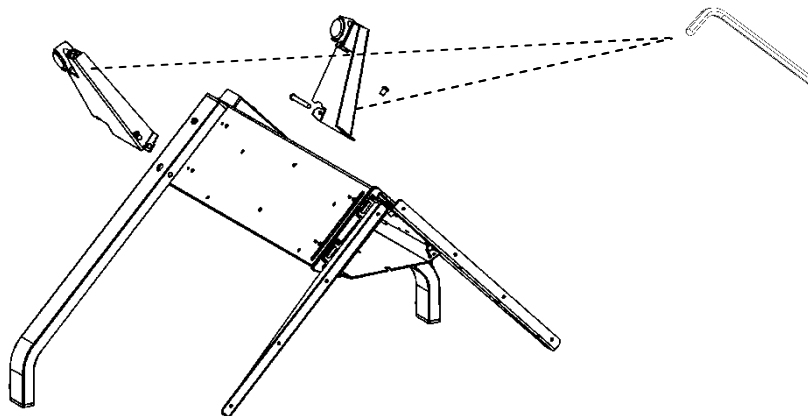

4

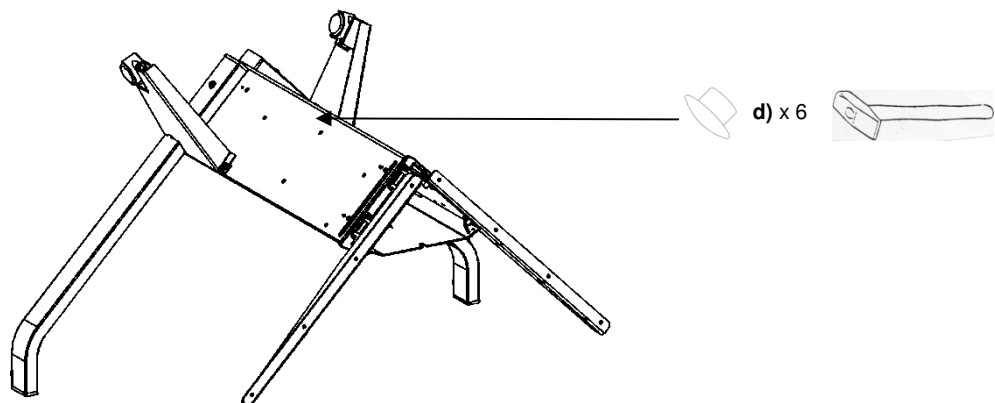

- b)** Mount tabletop, control box (white), power supply (black) and handset
- there are not any pre drilled holes in the tabletop

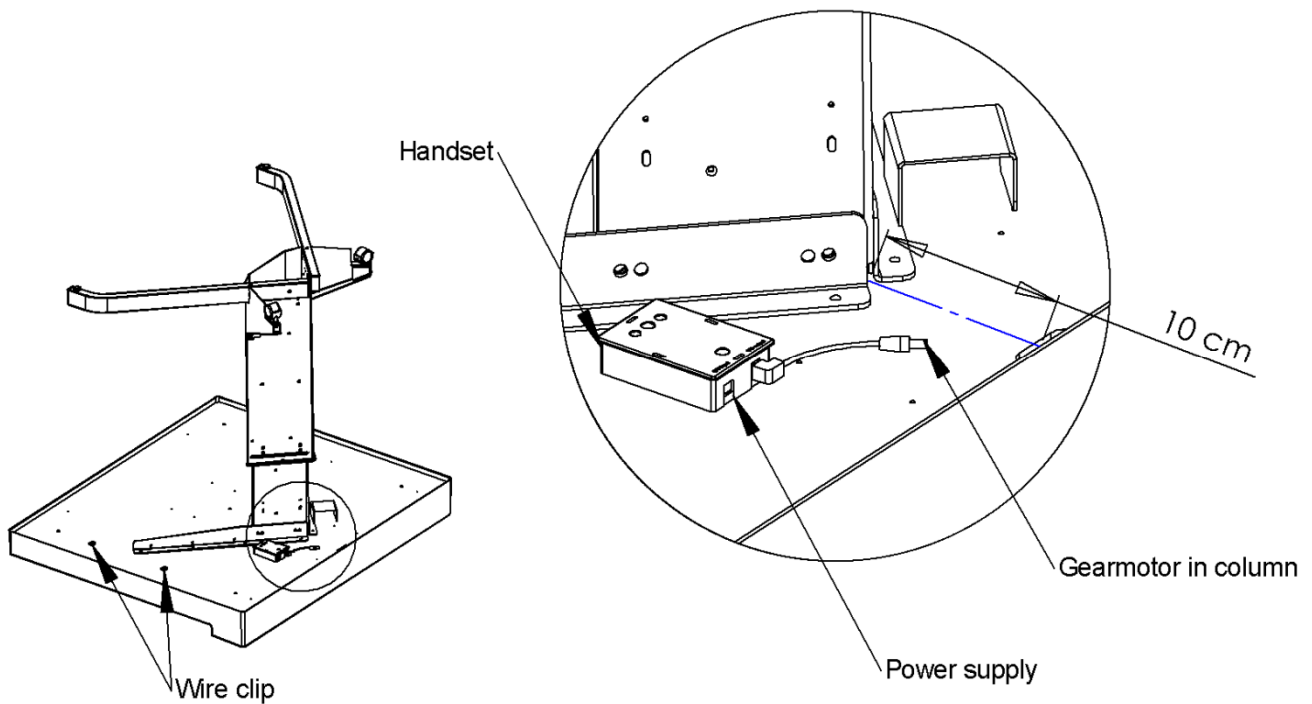

Important! The handset must be placed out of reach of children. It is the fitter's responsibility that this is the case!

- c)** Mount the wire basket in pre drilled holes (BSR 104)

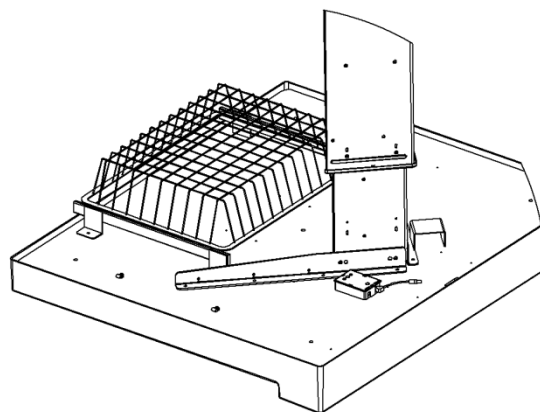

The changing table is now ready for use.

The fitter must instruct the staff in the proper use and the instructions of this manual.

9. DECLARATION OF CONFORMITY

We hereby declare, under our sole responsibility that the following products:

- ConSet changing table type BSR

which are covered by this statement, are in conformity with the following standards and other normative documents::

- Council Directive 98/37/EF
- Council Directive 89/336/EØF with later changes
- Council Directive 73/23/EØF with later changes

With reference to the Machinery Directive (98/37/EF) please be aware:

- The changing table is considered a machine and
- The changing table may not be used until it has been assembled and installed according to the instructions.

Manufacturer:

ConSet A/S
Stålvvej 14-16
DK-6900 Skjern
Danmark
Tel: +45 9680 0080, Fax: +45 9680 0081
www.conset.com
conset@conset.com